

[Return to Home Page](#)

Patrol Kitchen Box Plans

- [Perspective View and Front View](#)
- [Cross Section View and Assembly Instructions](#)
- [Tie Braces](#)
- [Legs](#)
- [Socket Blocks and Clamp Plate](#)
- [Materials List and Cutting Guides](#)
- [Return to Jamboree Page](#)

These plans are based upon the Patrol Food Chest designed by the BSA Engineering Service and recommended in the Jamboree Leader Guide. Dimensions have been altered to reflect the size of 2x4s at this point in time (1.5" x 3.5").

Note: the materials list shows how to cut all of the pieces out of one 4' x 8' sheet of 3/4" plywood and two 8' long 2" x 4" studs. The plywood should be exterior grade. If treated "outdoor wood" studs are used, read precautions regarding toxicity of wood and saw dust.

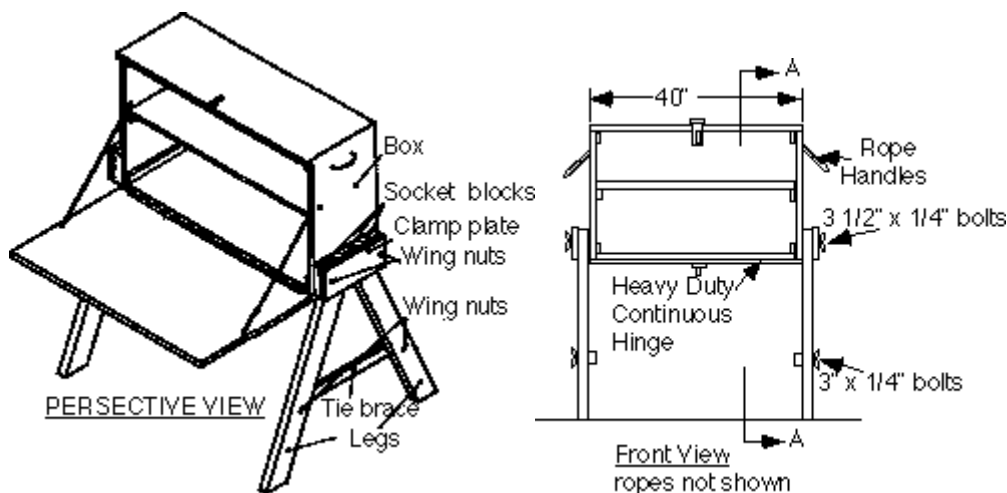

[Return to top.](#)

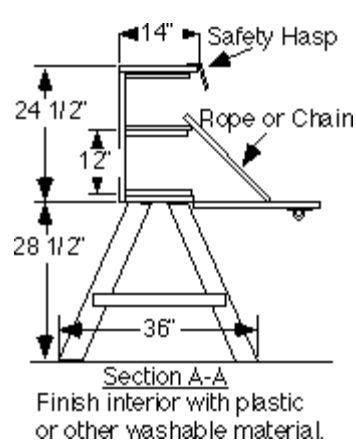

- ASSEMBLY**
1. Attach tie braces to legs, leave wing nuts loose.
 2. Loosen wing nuts on clamp plates.
 3. Insert legs in sockets & tighten wing nuts.
 4. Tighten tie brace nuts.
- Store legs and braces inside box.

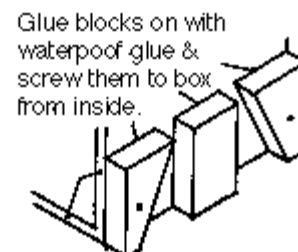

[Return to top.](#)

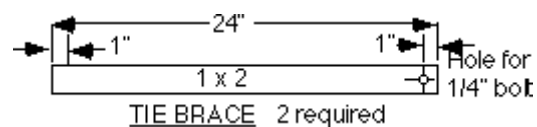

[Return to top.](#)

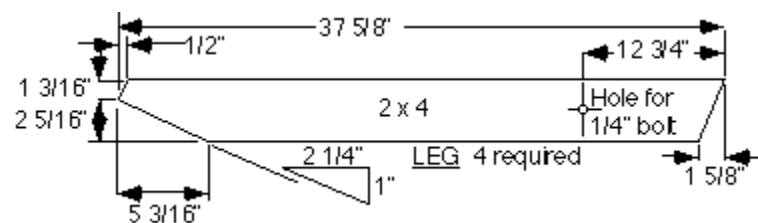

[Return to top.](#)

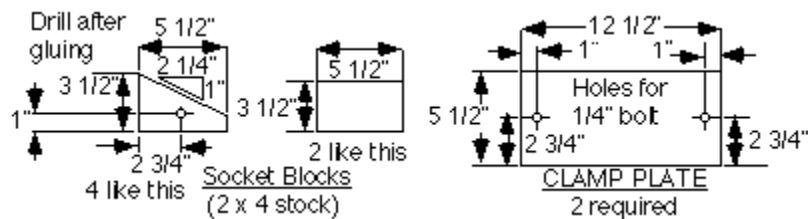

[Return to top.](#)

Materials List and Cutting Guide:

1 sheet 3/4" Plywood (4'x8')

(* save scrap for nailing strips)

2 - 8' - 2" x 4" (Legs & Socket Blocks)

1 - Heavy Duty Piano Hinge

1 - Hasp Set

4 - 3 1/2" x 1/4" bolts

4 - 3" x 1/4" bolts

8 - 1/4" wing nuts & washers

Plastic vaneer for interior

Rope for Handles

Rope or chain for drop front

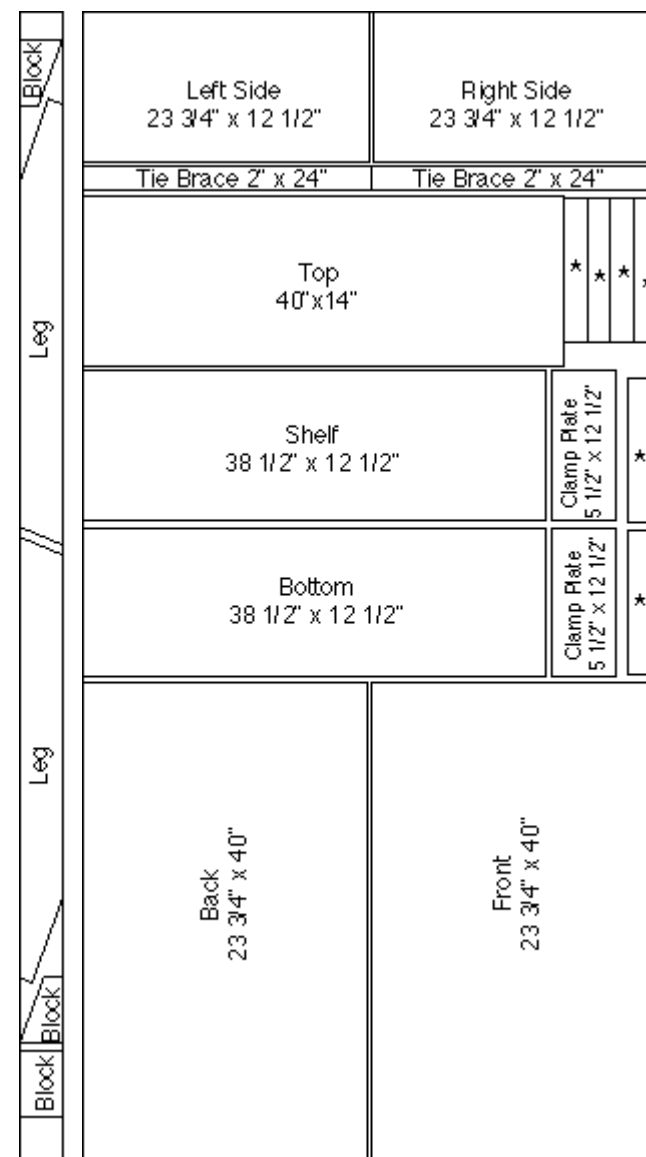

[Return to top.](#)

